

1 FRONT ELEVATION
CL-08B SCALE: NA

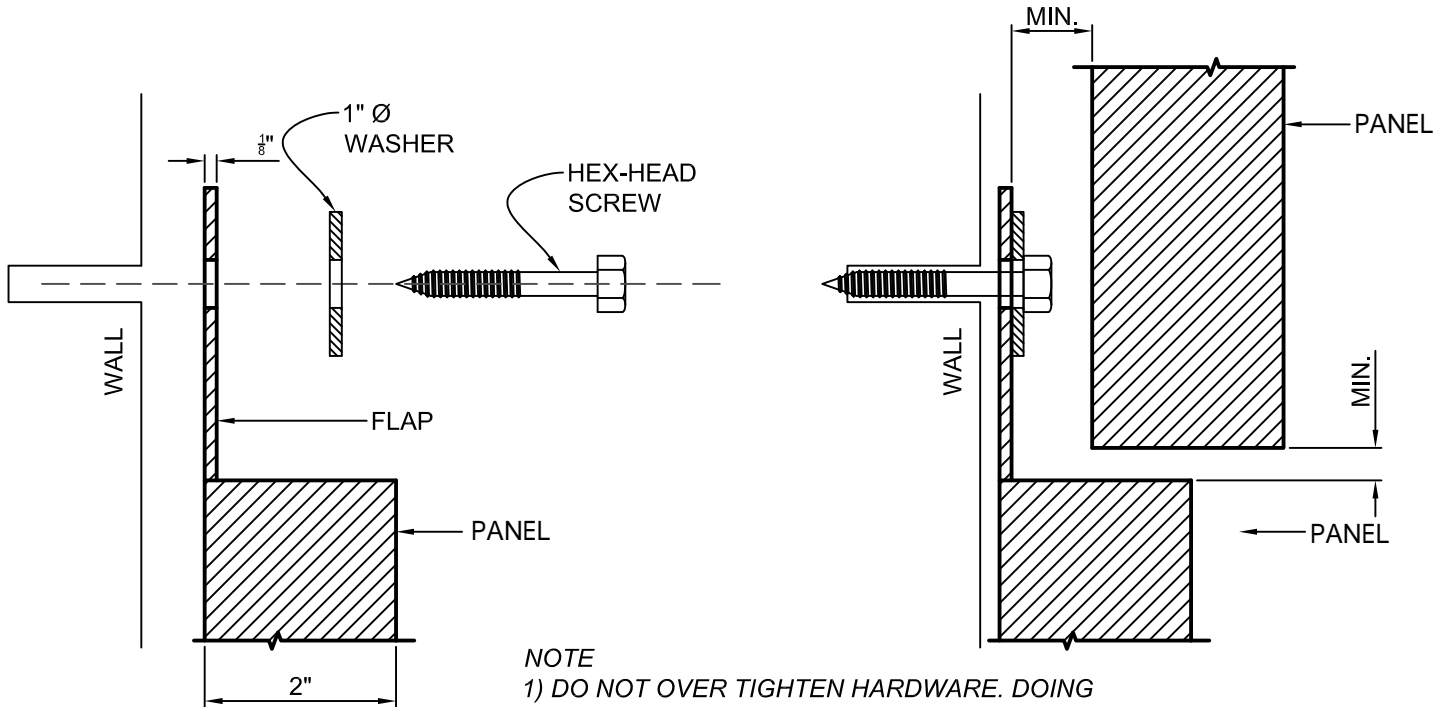

NOTE
1) DO NOT OVER TIGHTEN HARDWARE. DOING SO CAN CAUSE BOTTOM OF PANEL TO KICK OUT.

A ATTACHMENT DETAILS
CL-08B SCALE: NA

NOTE: DRAWINGS AND DETAILS ARE INTENDED TO PROVIDE GENERIC INSTALLATION GUIDELINES ONLY. ACTUAL FIELD CONDITIONS MAY VARY AND NEED TO BE CONFIRMED BY OTHERS.

| Revisions: | | |
|------------|-------|--------------|
| No. | Date: | Description: |
| | | |
| | | |
| | | |
| | | |

Sheet Description:
**Overlapping Flap Attachment
Wall Details**

| | |
|--------------|-----|
| Drawn By: | CPB |
| Checked By: | - |
| Approved By: | - |

| | |
|-------------------|---------------|
| Acoustical | |
| Date: | 05/25/10 |
| Scale: | VARIES |
| Drawing Ref: | None |
| Drawing: | CL-08b |

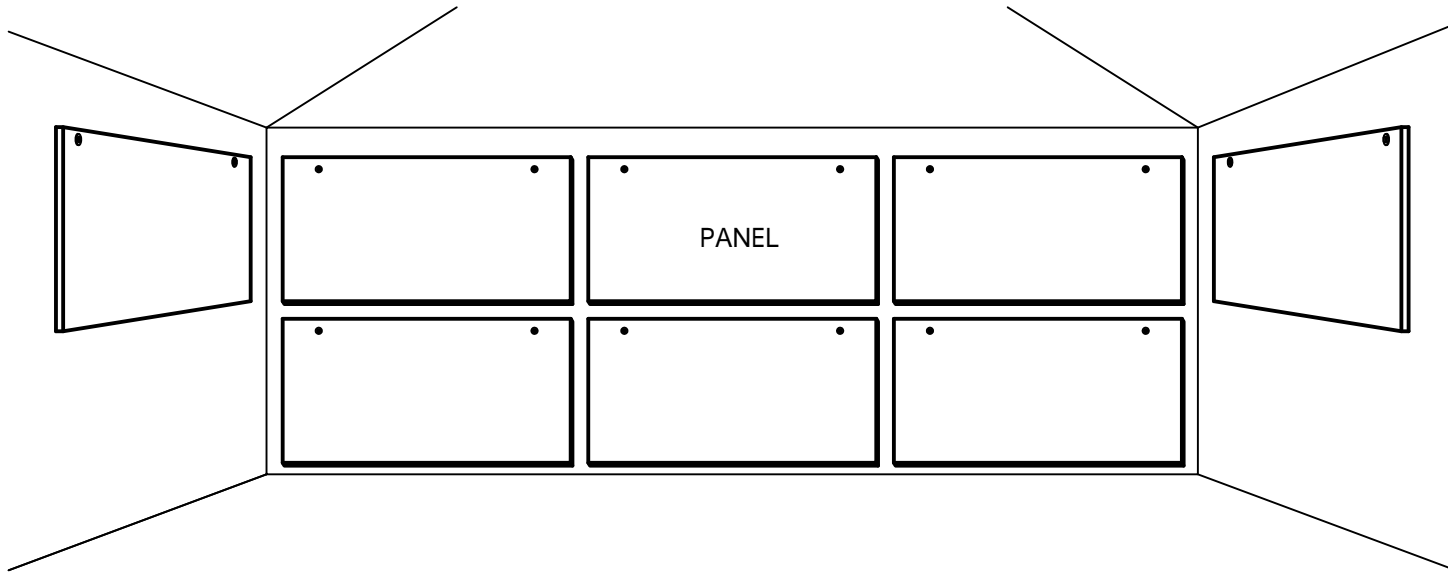

1 FRONT ELEVATION
CL-07 SCALE: NA

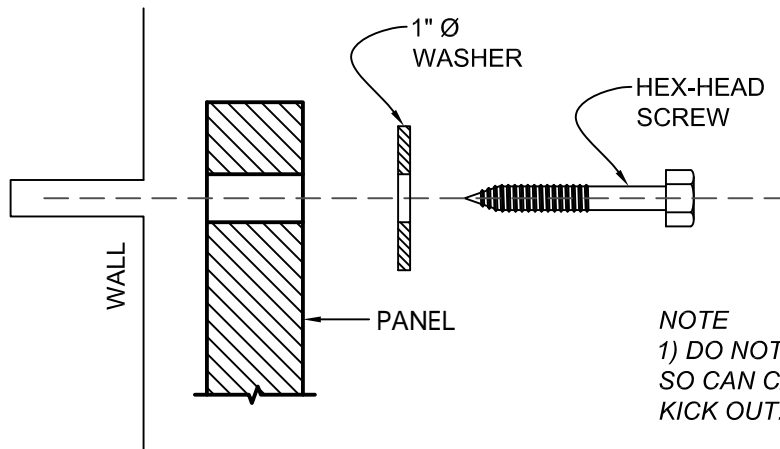

A ATTACHMENT DETAIL
CL-07 SCALE: NA

NOTE
1) DO NOT OVER TIGHTEN HARDWARE. DOING SO CAN CAUSE BOTTOM OF PANEL TO KICK OUT.

NOTE:
DRAWINGS AND DETAILS ARE INTENDED TO PROVIDE GENERIC INSTALLATION GUIDELINES ONLY. ACTUAL FIELD CONDITIONS MAY VARY AND NEED TO BE CONFIRMED BY OTHERS.

| Revisions: | | |
|------------|-------|--------------|
| No. | Date: | Description: |
| | | |
| | | |
| | | |
| | | |
| | | |
| | | |

Sheet Description:
Direct Wall Attachment Details

| | |
|--------------|-----|
| Drawn By: | CPB |
| Checked By: | - |
| Approved By: | - |

| | |
|-------------------|----------|
| Acoustical | |
| Date: | 01/28/09 |
| Scale: | VARIES |
| Drawing Ref: | None |
| Drawing: | CL-07 |

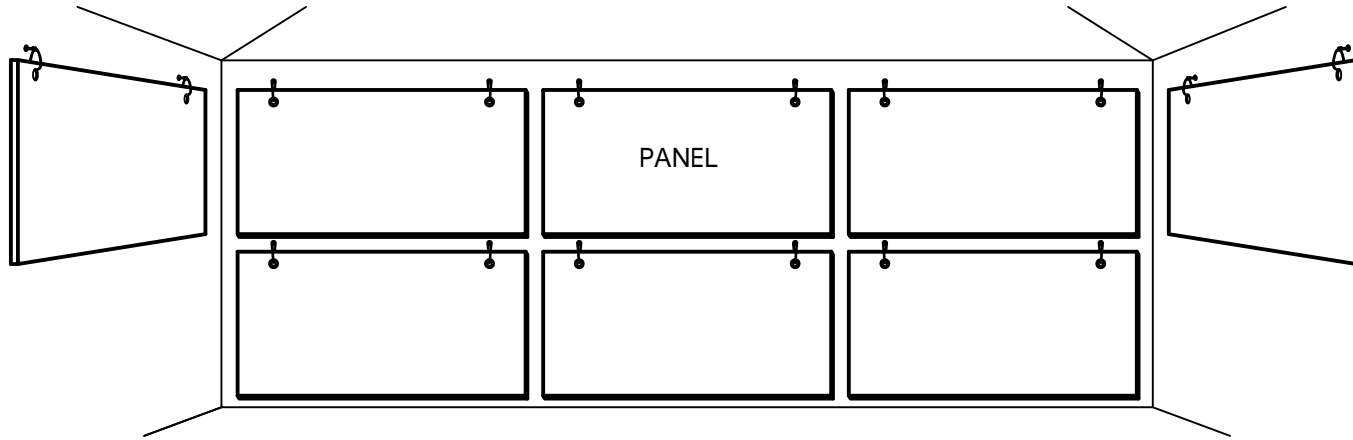

1 FRONT ELEVATION
CL-08 SCALE: NA

NOTE: DRAWINGS AND DETAILS ARE INTENDED TO PROVIDE GENERIC INSTALLATION GUIDELINES ONLY. ACTUAL FIELD CONDITIONS MAY VARY AND NEED TO BE CONFIRMED BY OTHERS.

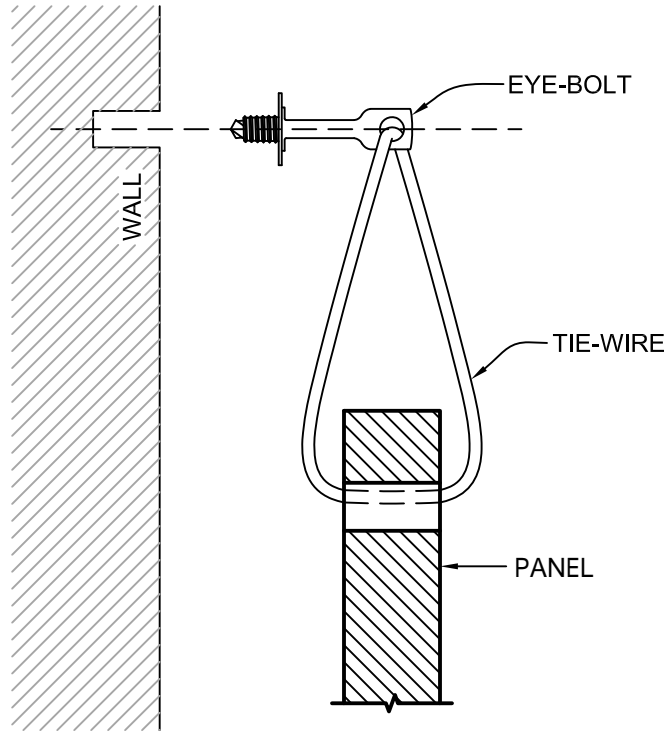

A ATTACHMENT DETAIL
CL-08 SCALE: NA

- NOTES:
- 1) PANEL ATTACHED TO EYEBOLTS WITH AIR SPACE FOR INCREASED ACOUSTICAL ABSORPTION. ATTACHMENT IS MADE WITH TIE WRAPS, TIE WIRES, OR APPROPRIATE FASTENERS.
 - 2) TIE-WIRE TO BE SNUGGED UP TIGHT TO CABLE SO TO PREVENT SLIPPAGE.

| Revisions: | | |
|------------|-------|--------------|
| No. | Date: | Description: |
| | | |
| | | |
| | | |
| | | |

Sheet Description:
Eyebolt & Hanger Wall Attachment Details

| | |
|--------------|-----|
| Drawn By: | CPB |
| Checked By: | - |
| Approved By: | - |

| | |
|-------------------|----------|
| Acoustical | |
| Date: | 01/28/09 |
| Scale: | VARIES |
| Drawing Ref: | None |
| Drawing: | CL-08 |

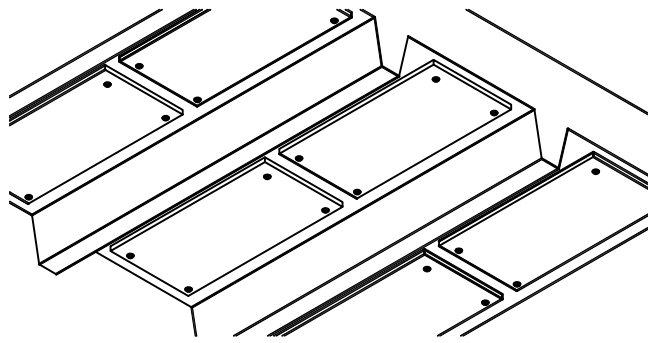

1 VIEW FROM BELOW
SP-02 SCALE: NA

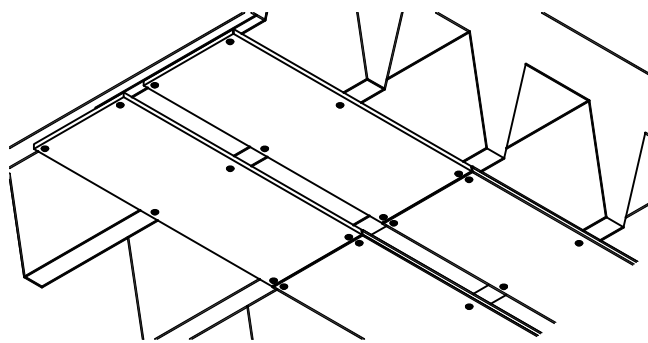

2 VIEW FROM BELOW
SP-02 SCALE: NA

NOTE:
1) CONFIRM COFFER DIMENSIONS PRIOR TO INSTALL.

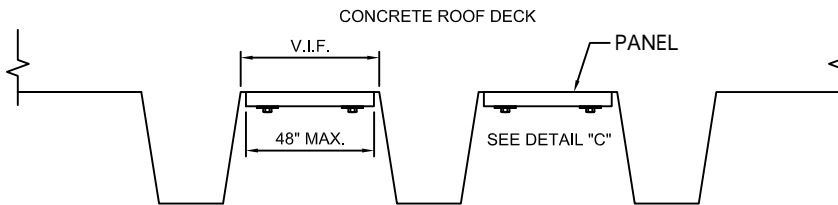

3 PANEL - TYP. ATTACHMENT DETAIL
SP-02 SCALE: NA

NOTE:
DETAIL DRAWN TO SHOW SUSPENSION ATTACHMENTS ONLY. IT IS NOT REPRESENTATIVE OF AN ACTUAL INSTALLATION.

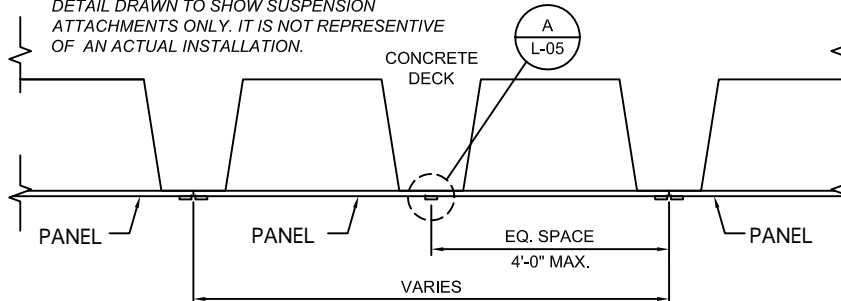

4 PANEL - TYP. ATTACHMENT DETAIL
SP-02 SCALE: NA

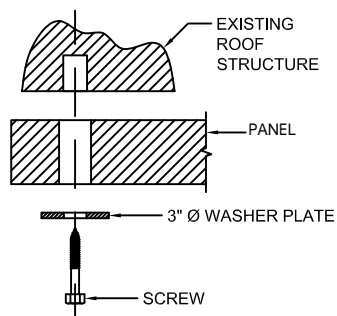

A HARDWARE ATTACHMENT DETAIL
SP-02 SCALE: NA

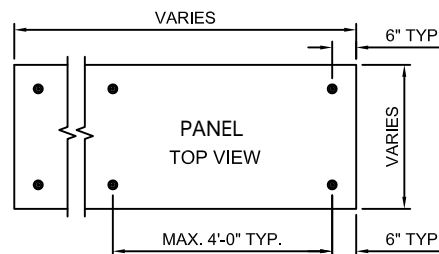

B WASHER PLATE DETAIL
SP-02 SCALE: NA

| Revisions: | | |
|------------|-------|--------------|
| No. | Date: | Description: |
| | | |
| | | |
| | | |
| | | |
| | | |

Sheet Description:
**Attach Direct to Concrete
w/ Washer Plates**

| | |
|-----------------------------------|--------------|
| Acoustical SOLUTIONS, INC. | |
| Drawn By: | CPB |
| Date: | 01/25/11 |
| Scale: | NA |
| Drawing Ref: | None |
| Drawing: | SP-02 |

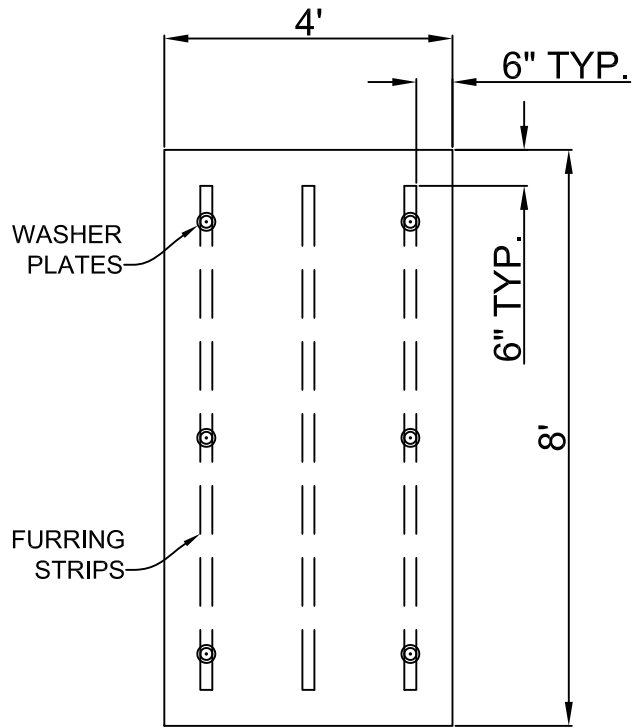

1 WALL MOUNT
SP-04 SCALE: NA

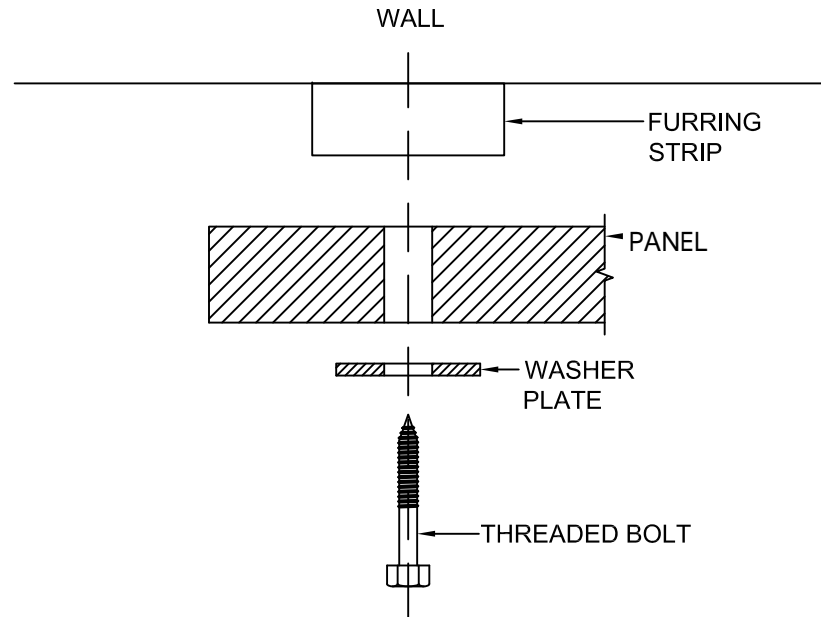

A ATTACHMENT DETAIL
SP-04 SCALE: NA

NOTE:
DETAILS DRAWN TO SHOW SUSPENSION ATTACHMENTS ONLY.
IT IS NOT REPRESENTATIVE OF AN ACTUAL INSTALLATION.

| Revisions: | | |
|------------|-------|--------------|
| No. | Date: | Description: |
| | | |
| | | |
| | | |
| | | |

Sheet Description:
**Wall Attachment
Details**

| | |
|--------------|-----|
| Drawn By: | CPB |
| Checked By: | - |
| Approved By: | - |

| | |
|--------------------------------------|-------------|
| Acoustical SOLUTIONS, INC. | |
| Date: | 04/02/09 |
| Scale: | VARIES |
| Drawing Ref: | None |
| Drawing: | S-04 |

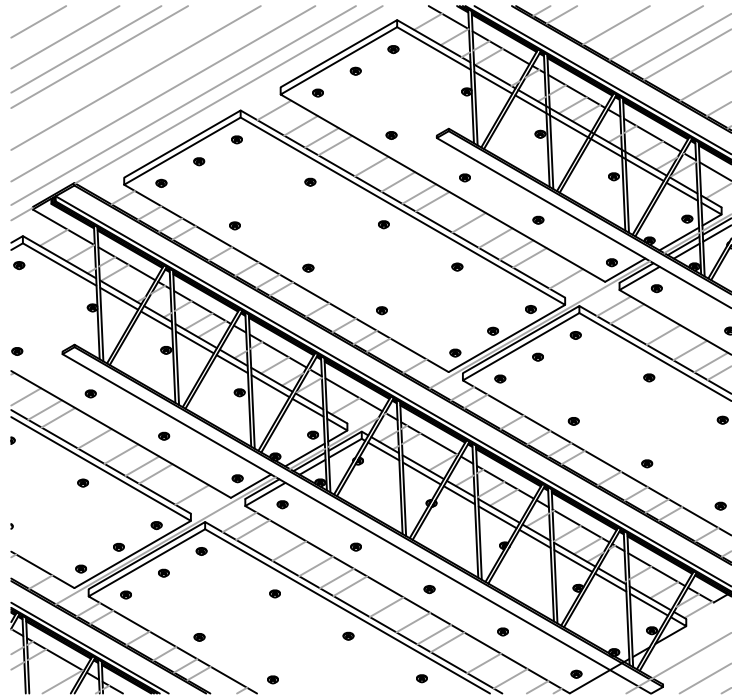

1
L-07
VIEW FROM BELOW
SCALE: NA

NOTES:

1) 1/L-07 ILLUSTRATES A SNUG ATTACHMENT OF PANELS USING 3"Ø COLOR-MATCHED WASHER PLATES FASTENED DIRECTLY TO THE UNDERSIDE OF A DECK OR CEILING.

2) THERE IS APPROXIMATELY 3" OF FESTOON BETWEEN 4'-0" ON CENTER ATTACHMENT POINTS.

NOTE:

DRAWINGS AND DETAILS ARE INTENDED TO PROVIDE GENERIC INSTALLATION GUIDELINES ONLY. ACTUAL FIELD CONDITIONS MAY VARY AND NEED TO BE CONFIRMED BY OTHERS.

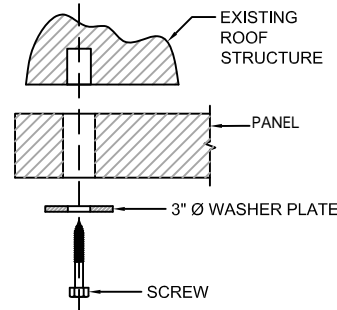

A
L-07
HARDWARE ATTACHMENT DETAIL
SCALE: NA

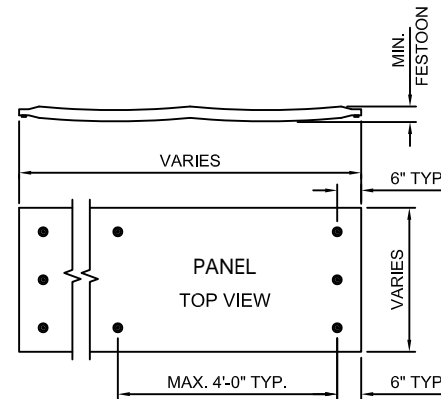

NOTE: MIN. FESTOON DEPTH REQUIREMENTS ARE DEPENDENT ON THE OVERALL LENGTH

B
L-07
WASHER PLATE DETAIL
SCALE: NA

NOTE:

1) DUE TO THE NATURE OF THIS PRODUCT, FESTOON DEPTH MAY VARY. ADJUSTMENTS MAY BE NECESSARY.

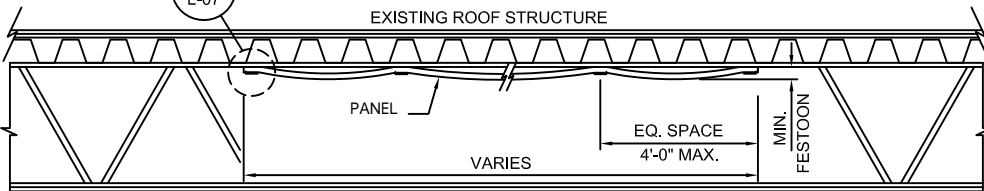

2
L-07
HORZ. - TYP. ATTACHMENT DETAIL
SCALE: NA

NOTE:

DETAIL DRAWN TO SHOW SUSPENSION ATTACHMENTS ONLY. IT IS NOT REPRESENTATIVE OF AN ACTUAL INSTALLATION.

| Revisions: | | |
|------------|-------|--------------|
| No. | Date: | Description: |
| | | |
| | | |
| | | |
| | | |

Sheet Description:
Washer Plate Attachment to Roof Deck Details

| | |
|--------------|-----|
| Drawn By: | CPB |
| Checked By: | - |
| Approved By: | - |

| | |
|-----------------------------------|-------------|
| Acoustical SOLUTIONS, INC. | |
| Date: | 1/24/11 |
| Scale: | VARIES |
| Drawing Ref: | None |
| Drawing: | L-07 |