

**AUTOMATIC DOOR BOTTOM DATA SHEET**



**DESCRIPTION**

Our Automatic Door Bottom utilizes a flat spring mechanism that activates when closing the door, lowering a neoprene seal insert against the floor or threshold to create a sound seal. These are for use on the push side of the door. The frame compresses a protruding hinge-side “plunger” as the door closes to activate the spring. The Automatic Door Bottom then drops a seal in a scissor-like motion from the hinge side, adjusting to the floor from a pivoting point. As the neoprene seal compresses, it forms a tight, secure seal against the saddle or floor. The sweep retracts automatically as the door opens.

Our Automatic Door Bottoms can be made to fit any sized door up to 48". We offer a surface-mounted unit, as well as a mortised and semi-mortised version. These door bottoms are available with a clear anodized aluminum or dark bronze anodized aluminum finish. Automatic door bottoms are often used in conjunction with door seals and acoustic thresholds.

**TECHNICAL CHARACTERISTICS**

- SIZE:** Lengths up to 48"
- FINISH:** Aluminum, Dark Bronze
- TYPE:** Surface Mount  
Semi-Mortised  
Mortised (Aluminum Only)

**SEAL:** Solid Neoprene Rubber

- MAXIMUM DROP:** 367 - Up to 1/2"
- 366 - Up to 1"
- 369 - Up to 1/2"

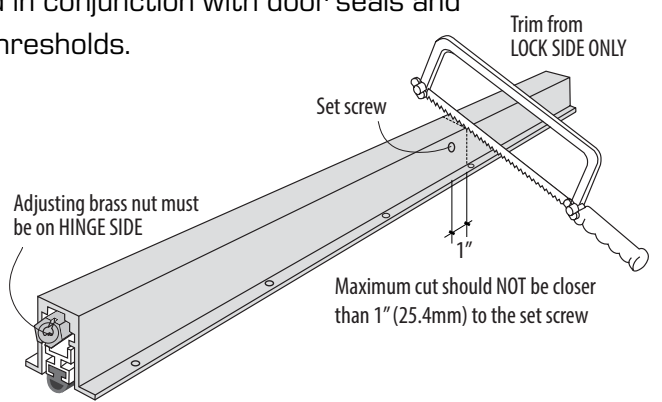

**SURFACE MOUNT**



#367

**SEMI-MORTISED**



#366

**MORTISED**



#369

